

UNIMOTION

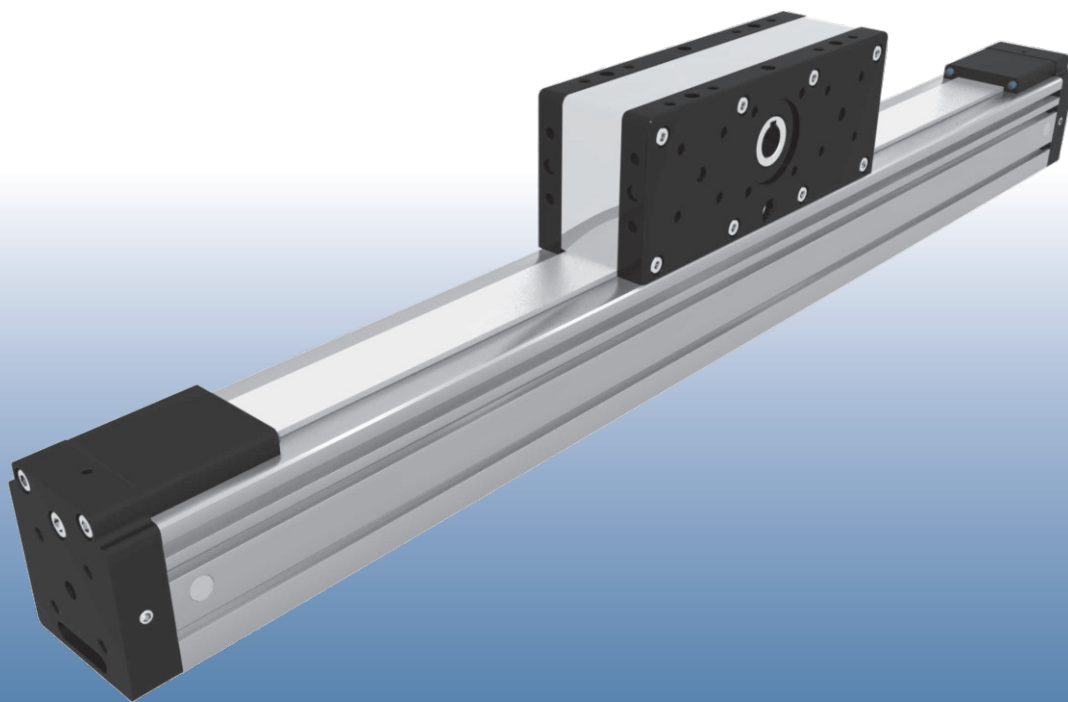

MAINTENANCE - AND ASSEMBLY INSTRUCTIONS

MTJZ SERIES

Hypex d.o.o.
Alpska cesta 43, 4248 Lesce
Slovenia

Tel: +386 (0)4 531 8700 Fax: +386 (0)4 531 8740
www.unimotion.eu e-mail: sales@unimotion.eu

www.unimotion.eu

NOTES

TABLE OF CONTENTS

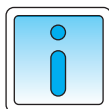

CONTENTS

PAGE

GENERAL INFORMATION	—	—	—	—	—	1.005.0
Used symbols	—	—	—	—	—	1.005.0
Tightening torques	—	—	—	—	—	1.005.0
General safety instructions	—	—	—	—	—	1.005.0
Safe operation	—	—	—	—	—	1.005.0
Modification of the linear unit	—	—	—	—	—	1.010.0
Labels and notices	—	—	—	—	—	1.010.0
Warranty	—	—	—	—	—	1.010.0
Handling the linear unit	—	—	—	—	—	1.015.0
Product description	—	—	—	—	—	1.025.0
Overview	—	—	—	—	—	1.030.0
MOUNTING	—	—	—	—	—	1.030.0
Fixing system	—	—	—	—	—	1.030.0
Magnetic field sensor	—	—	—	—	—	1.035.0
Mechanical and inductive switch	—	—	—	—	—	1.040.0
Motor with coupling	—	—	—	—	—	1.045.0
MAINTENANCE	—	—	—	—	—	1.050.0
Lubrication of drive block	—	—	—	—	—	1.050.0
Lubricant	—	—	—	—	—	1.050.0
Lubricant quantities and intervals	—	—	—	—	—	1.050.0
Normal operating conditions	—	—	—	—	—	1.050.0
ASSEMBLIES	—	—	—	—	—	1.055.0
MTJZ 40	—	—	—	—	—	1.055.0
MTJZ 65	—	—	—	—	—	1.060.0
MTJZ 80	—	—	—	—	—	1.065.0
MTJZ 110	—	—	—	—	—	1.070.0
REPLACEMENT OF ASSEMBLIES MTJZ SERIES	—	—	—	—	—	1.075.0
Loosening the belt	—	—	—	—	—	1.075.0
Removing tension blocks	—	—	—	—	—	1.075.0
Replacing the toothed belt	—	—	—	—	—	1.080.0
Tensioning the toothed belt	—	—	—	—	—	1.080.0
Replacing the axles and/or drive block	—	—	—	—	—	1.085.0
Replacing the carriage	—	—	—	—	—	1.085.0
Replacing the rail	—	—	—	—	—	1.090.0

GENERAL INFORMATION

USED SYMBOLS



Remark, note



Warning!



Danger!

Risk of coming into contact with power conducting parts! Cut off power supply!



Caution!

Keep Linear Unit clean!
Cover it, if necessary!



For more information see the catalogue



Do not use glue in the current step



Use dedicated tools for the current step



Use different tightening torque than in the table on page 1.005.0

TIGHTENING TORQUES

Following tightening torques are recommended for screws of strength class 8.8

8.8	M2	M2,5	M3	M4	M5	M6	M8	M10	M12
M_{max} [Nm]	0.4	0.7	1.3	2.8	5.6	9.6	23	45	74



Screw



Tightening torque

GENERAL SAFETY INSTURCTIONS

To ensure the right functionality of the MTJZ Linear Unit, it must be handled with care. It is not allowed to put any tools or any other items which can cause damage to the linear unit on the linear unit.

The Linear Unit must be protected against any liquid that can cause damage to it.

The MTJZ Linear unit must be placed in a dry, clean environment. For information on the conditions in which the linear module can operate please contact us.

If the Linear Unit isn't in use, place it in a dry, clean environment and cover it to prevent any damage.

SAFE OPERATION

The Linear unit must not be put into service until the final machinery into which it is installed has been declared in conformity with the provisions of the Machinery Directive, where appropriate

.Each operation of the Linear Unit that is not in compliance with its intended use can lead to the product being damaged, accidents and at the same time stoppages in production. To ensure a safe operation please refer to this Instruction Manual and the operating manual of other machinery where the Linear Unit is to be incorporated.

The linear unit satisfies the requirements of EC Machinery Directive 2006/42/EC according to the European or national standards of Safety of machinery:

- EN ISO12100-1
- EN ISO 12100-2

⚠ Checking the linear unit

In accordance with the EU Health and Safety Directive 89/655/EEC article 4a, the operating company must subject the unit to thorough checking prior to putting it into operation, after carrying out repairs, and after malfunctions have occurred.

⚠ Requirements for personnel

The linear units may only be installed, operated, maintained, repaired or dismantled by appropriately qualified personnel in accordance with the specification in this manual. All qualified personnel must have read and understood this Instruction manual.

MODIFICATION OF THE LINEAR UNIT

The linear unit must not be modified without our written consent. Any such unauthorized modification will void our liability in respect of the unit. The operating company may only carry out the maintenance and repair work detailed in this Instruction manual.

LABELS AND NOTICES

All notices and labels attached to the linear unit must be fully visible and must not be allowed to be removed. They must ensure compliance with all the instructions contained on them. Damaged or illegible notices and labels must be replaced.

WARRANTY

The warranty conditions are laid down in the terms and conditions of delivery and payment issued at time of the order. Warranty cover will be annulled if:

- the unit is not operated in accordance with the stipulated regulation use;
- the instructions set out in this operating manual are not followed;
- the unit is modified without the consent of the manufacturers;
- the screws sealed by locking varnish are unlocked.

The manufacturer's warranty in respect of maintenance and repair work applies only if original replacement parts are used.

HANDLING THE LINEAR UNIT

The Linear units are carefully packed in a HARD WOODEN BOX for a safe transportation.

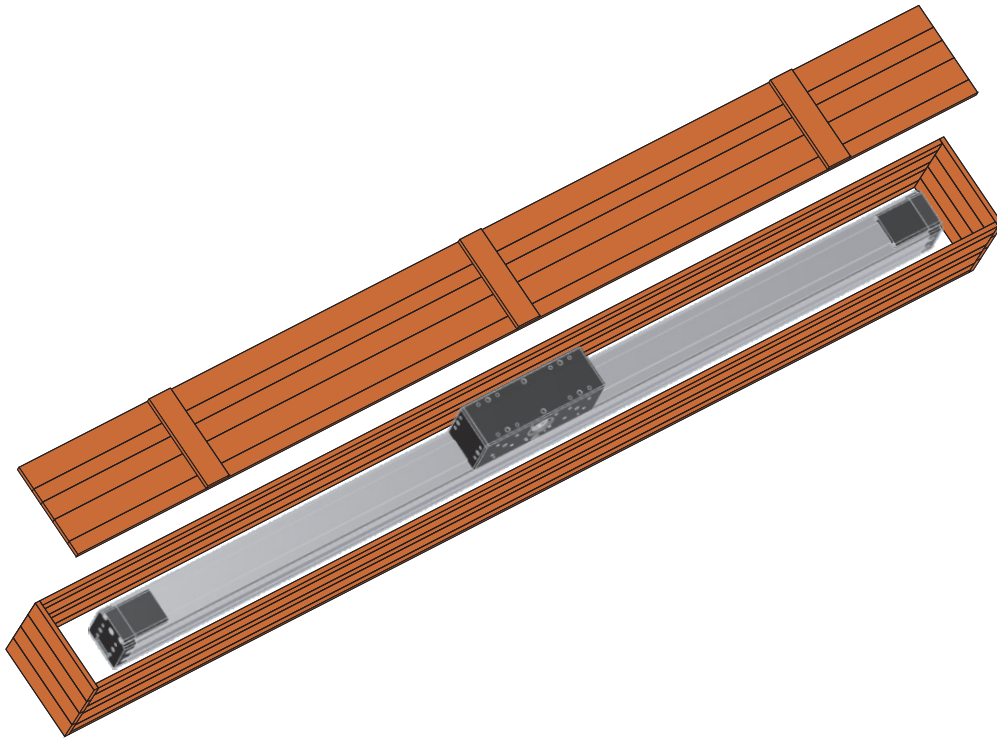

To take the Linear Unit out of the box, please consider the following handling instructions:

- Never lift the Linear Unit by the END BLOCKS - see PICTURE A
- Never grab by the TIMING BELT of the Linear Unit
- Never grab by the DRIVE BLOCK

To take the Linear Unit out of the box, a suitable lifting tool is needed. Always lift and carry the Linear Unit by the main profile.

The Linear Unit must be supported all the time during the handling until it is fixed - mounted on the place, where it is meant to be. For correct handling please refer to page number 1.020.0

PICTURE A is showing, that handling with the Linear Unit in this position is wrong, because the profile, guides and other components might get deflected or damaged.

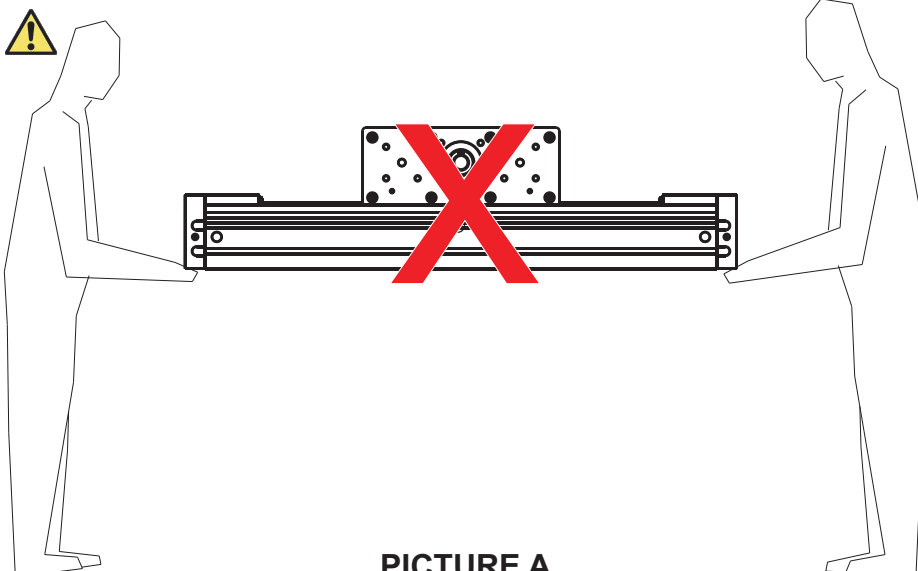

⚠ Carrying the Linear Unit holding the END BLOCKS isn't allowed, it must be carried holding the PROFILE of the Linear Unit.

PICTURE A

PICTURE B is showing correct handling of the Linear Unit.

PICTURE B
 $L < 2000\text{mm}$

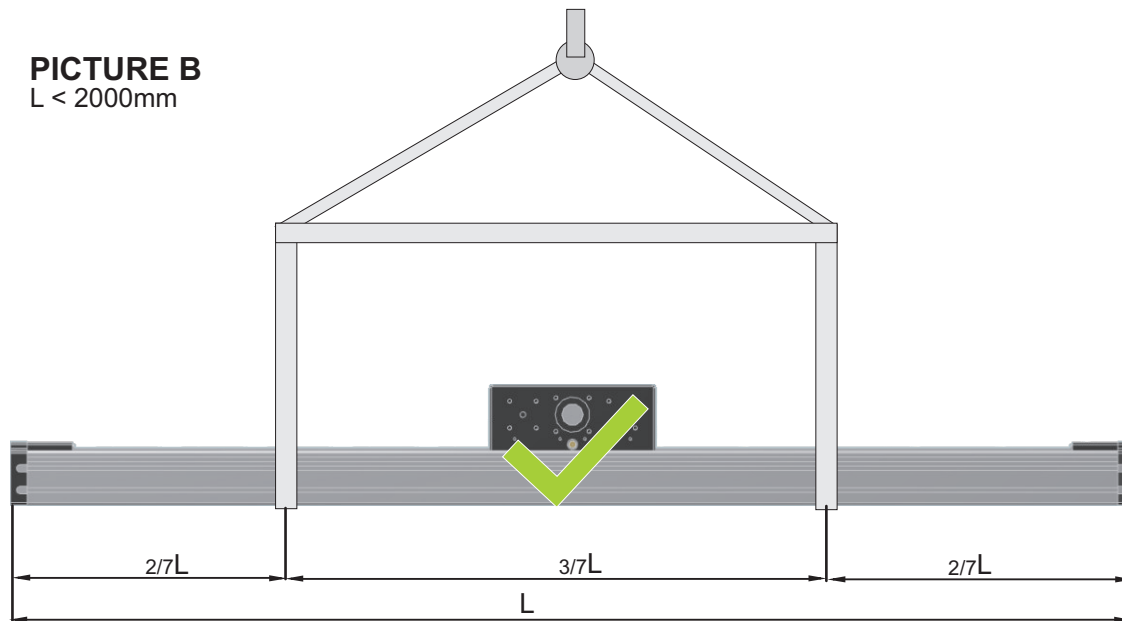
**WARNING**

Calculate the weight of the linear unit in order to choose the suitable lifting tool for the transportation of the Linear Unit.

Please refer to the catalogue UNIMOTION - LINEAR UNITS for weight calculations.

Linear Unit needs to be stored in dry place and protected against corrosion. Make sure that there is no danger for the Linear Unit to get damaged.

PRODUCT DESCRIPTION

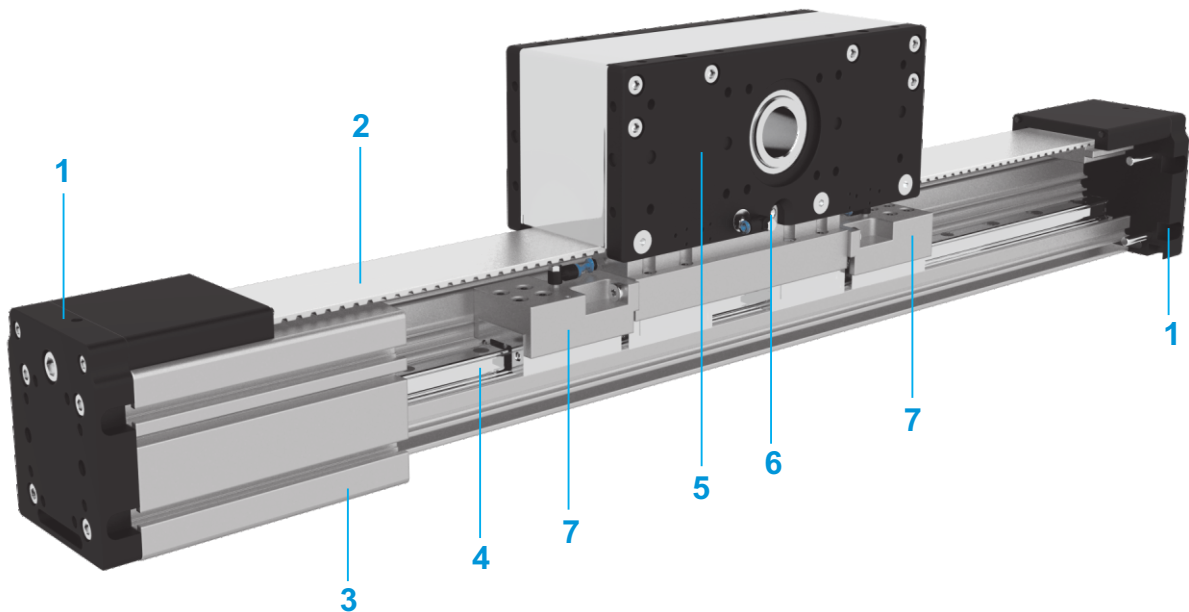

- 1 - Tension End with integrated belt tensioning system
- 2 - AT polyurethane toothed belt with steel tension cords
- 3 - Aluminium profile - hard anodized
- 4 - Linear Ball Guideway
- 5 - Drive block with pulley, motor flange; with built in Magnets
- 6 - Central lubrication port; both sides
- 7 - Clamping element - emergency brake (MTJZ 110 only)

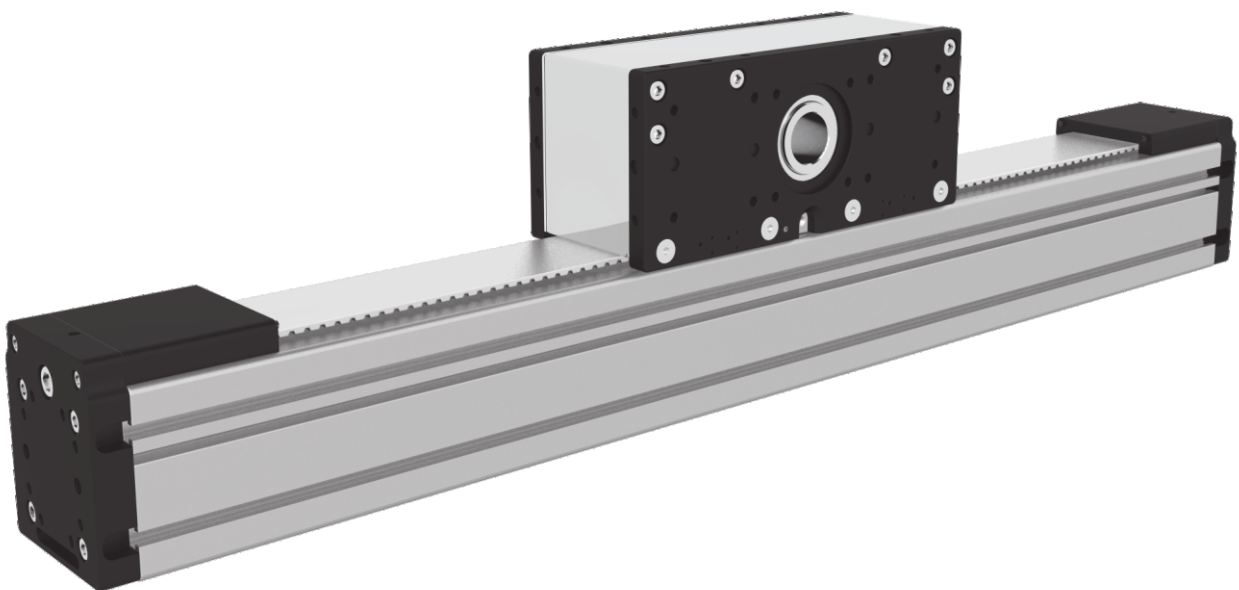

OVERVIEW

Identification label and additional or replacement parts of the Linear Unit

- 1 - ID number
- 2 - Serial number
- 3 - Type of Linear Unit (ordering code)



In the case of ordering additional or replacement parts for the Linear Unit all data from the identification label must be given.

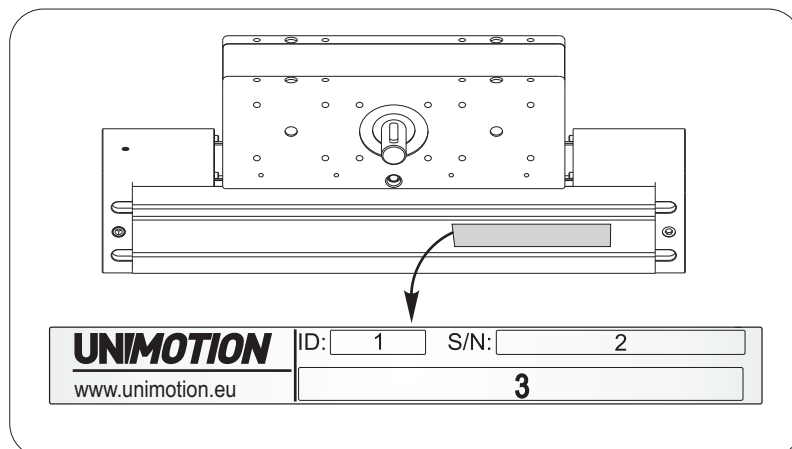

The label must be fully visible (in particular details of the serial number) and must ensure compliance with all the instructions contained on it. Damage and illegible labels must be replaced.

MOUNTING

Fixing system



Module can be mounted by drive block on any side.

Additional mounting points for workpiece or tools are on the end blocks. It is also possible to mount something to the profile of the linear unit, however clamps must be used in this case.

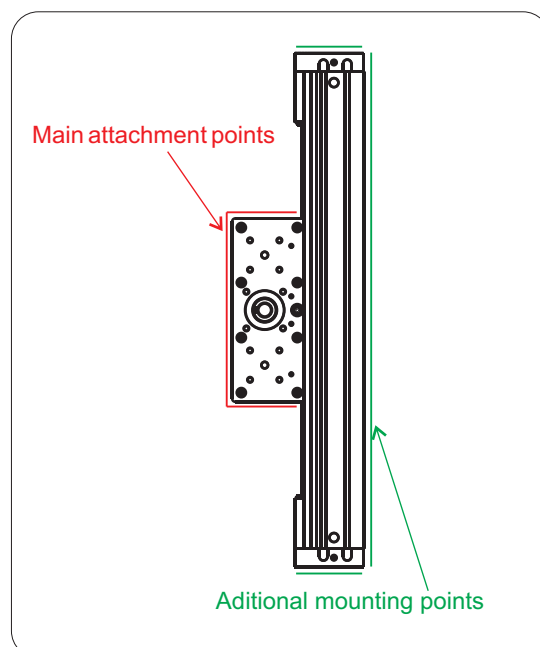

For the tightening torques for the screws please refer to page number 1.005.0

MOUNTING

Magnetic field sensor - REED SWITCH

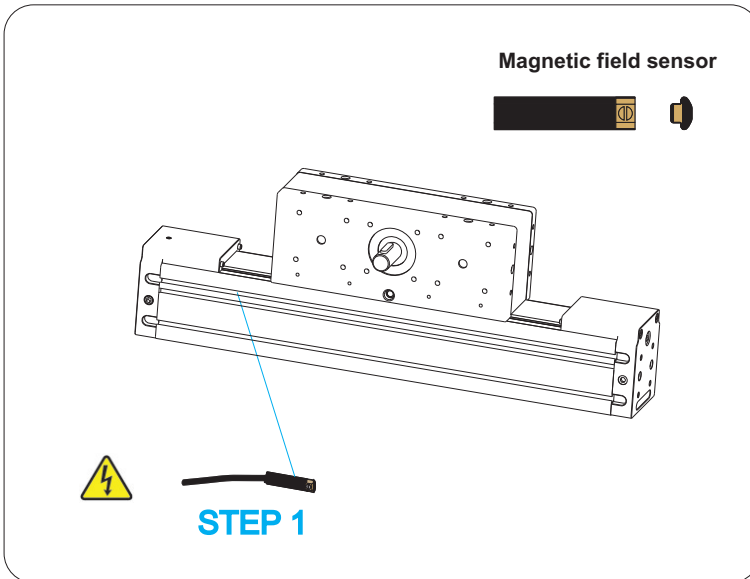

STEP 1: Placing of the magnetic field sensor can be done on the left or right side of the profile of the Linear Unit.

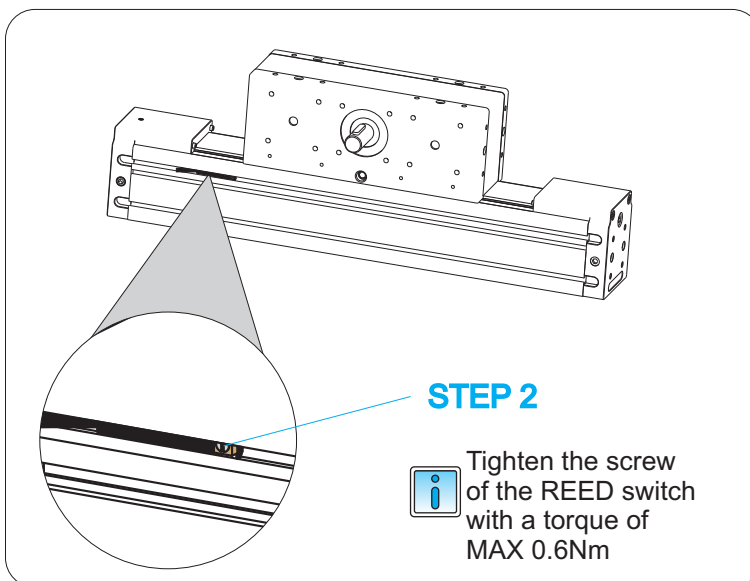

STEP 2: After the switch is placed into the groove, tighten the screw.

MOUNTING

Mechanical and Inductive switch

STEP 1: Mount the activation block to the drive block in a desired location. The activation block can be mounted on the left or right side. After the activation block is placed in the desired location, tighten the screws.

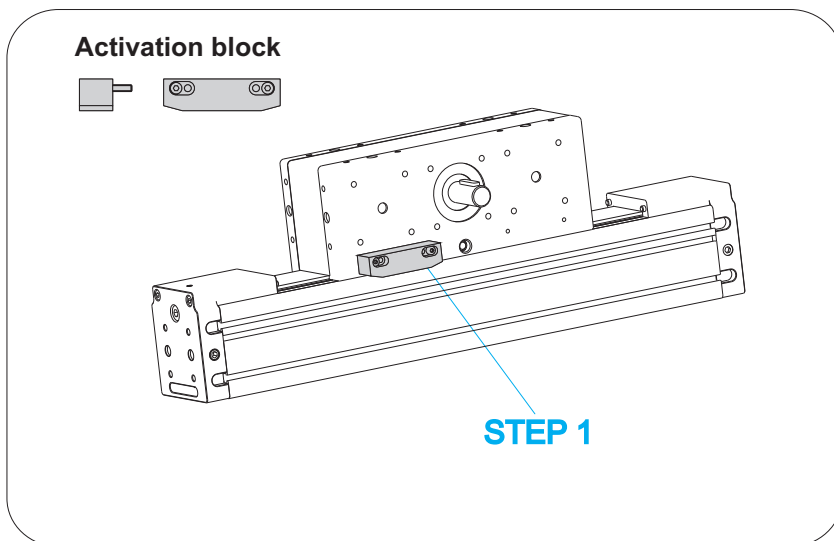

STEP 2: Place either the mechanical switch or the inductive switch with brackets in the slots and position them in the desired location. The mechanical or inductive switch with brackets can be placed in the slots either on the left or right side of the profile of the Linear Unit.

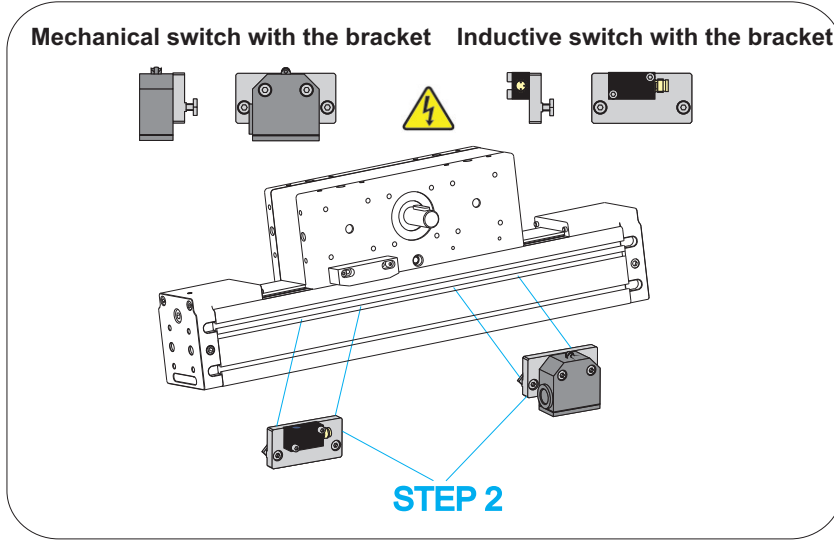

STEP 3: After the mechanical or inductive switch with bracket is placed in the desired place in the slots, tighten the screws of the bracket.

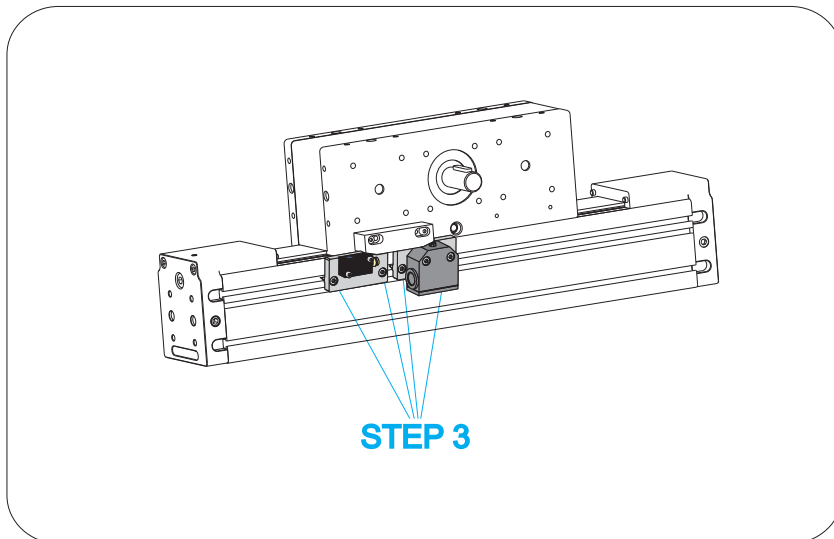

For the tightening torques for the screws please refer to page number 1.005.0

MOUNTING

Motor with coupling

If motor adapter has inner through hole of the same size its entire length.

STEP 1: Attach one half of the coupling to the shaft of the linear unit and other to the shaft of the motor.

Insert coupling spider into one half of the coupling.

STEP 2: Attach motor adapter to the linear unit.

STEP 3: Attach motor to the motor adapter.

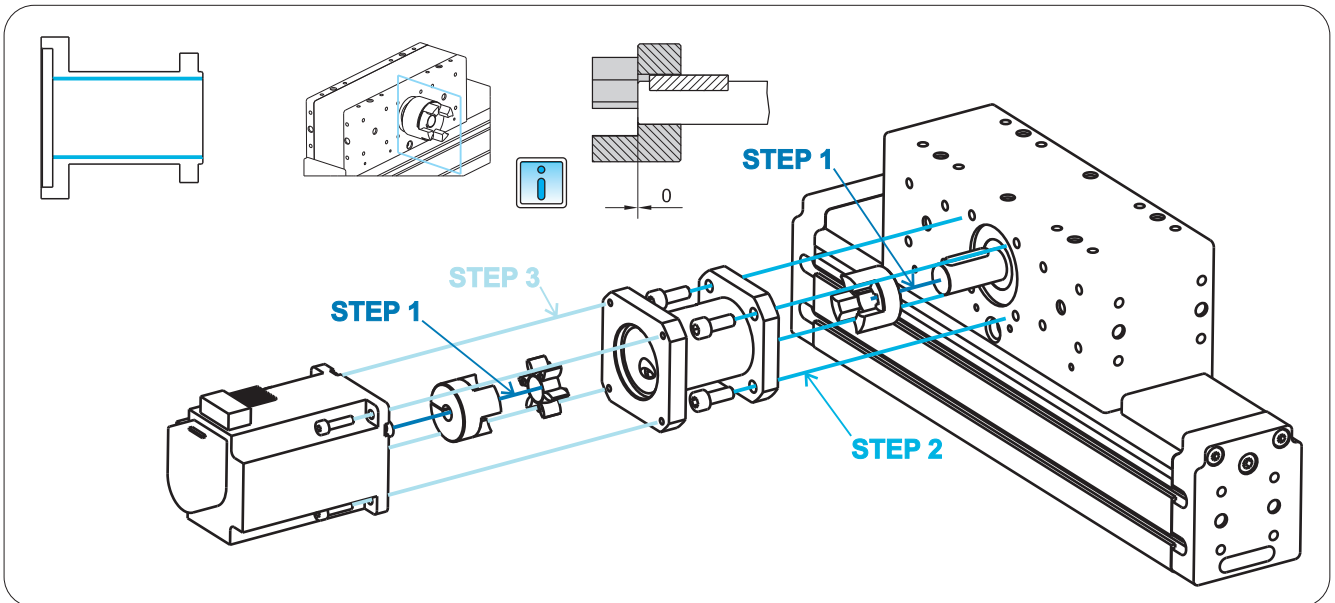



If motor adapter has inner through hole with the narrowing at one end.

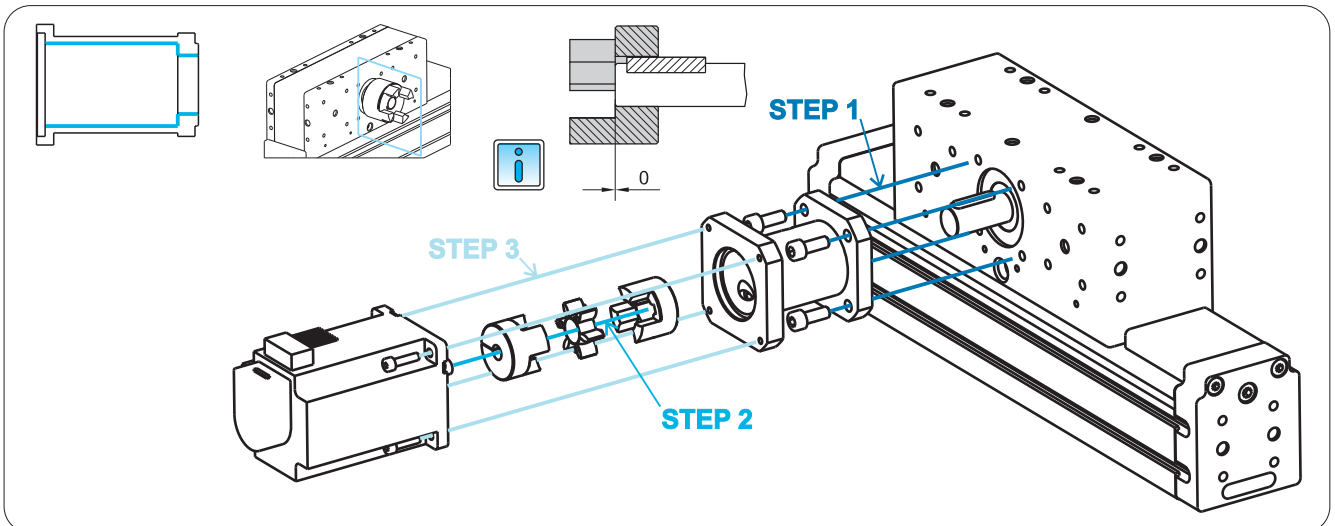

STEP 1: Attach motor adapter to the side on which the through hole is narrower.

STEP 2: Attach complete coupling to the axle on the wider side of the hole.

STEP 3: Assemble two parts together and tighten the remaining screw on the coupling through appropriate hole in motor adapter.



Tighten the screws on the coupling halves with coupling tightening torque. 

 The maximum torque and maximum speed of the motor must never exceed the limits of the Linear Unit! 

 For the tightening torques for the screws please refer to page number 1.005.0

MAINTENANCE



For each Linear Unit the basic lubrication is done in the factory before shipment. All bearings have been lubricated for life and do not require any additional lubrication under normal operating conditions.

Lubrication of the drive block

Drive block lubrication is done via lubricating nipple DIN 3405 D at the bottom center of the drive block.

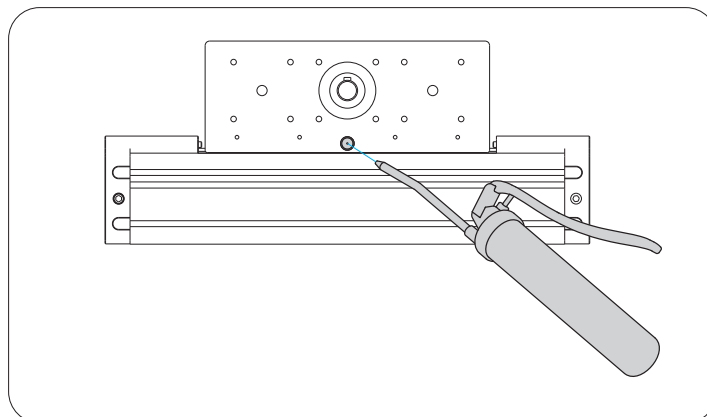

Lubricant

Recommended grease for MTJZ

Lubcon TURMOGREASE LC 802 EP



For lubrication and re-lubrication of linear units a grease lubricant must only be used! Do not use grease which contains any solid parts!

Lubricant quantities and intervals

MTJZ	Travel path [km]	Grease - relubricating quantity [cm ³] Driving block
65	5000	0.7
80	5000	1.4
110	10000	1.4



The stated lubrication intervals in the table above are sufficient for normal operating conditions. If you have special operating systems please contact us.

Lubrication intervals are every 500 operating hours or after the specified travel path stated in the table above. It depends on which value is reached first.

Normal operating conditions

Temperature: 10 °C - 30 °C

Travel speed: MTJZ 3 m/s

Stroke: MTJZ 40 > 50 mm
 MTJZ 65 > 60mm
 MTJZ 80 > 60 mm
 MTJZ 110 > 60 mm

Load: ≤ 0.2 C

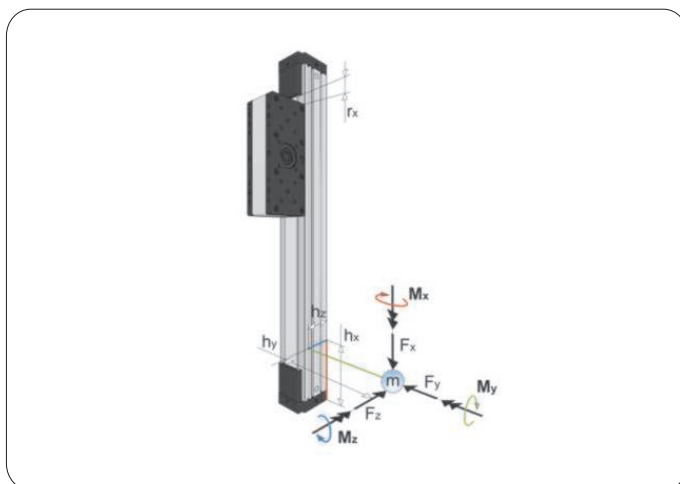

ASSEMBLY MTJZ 40

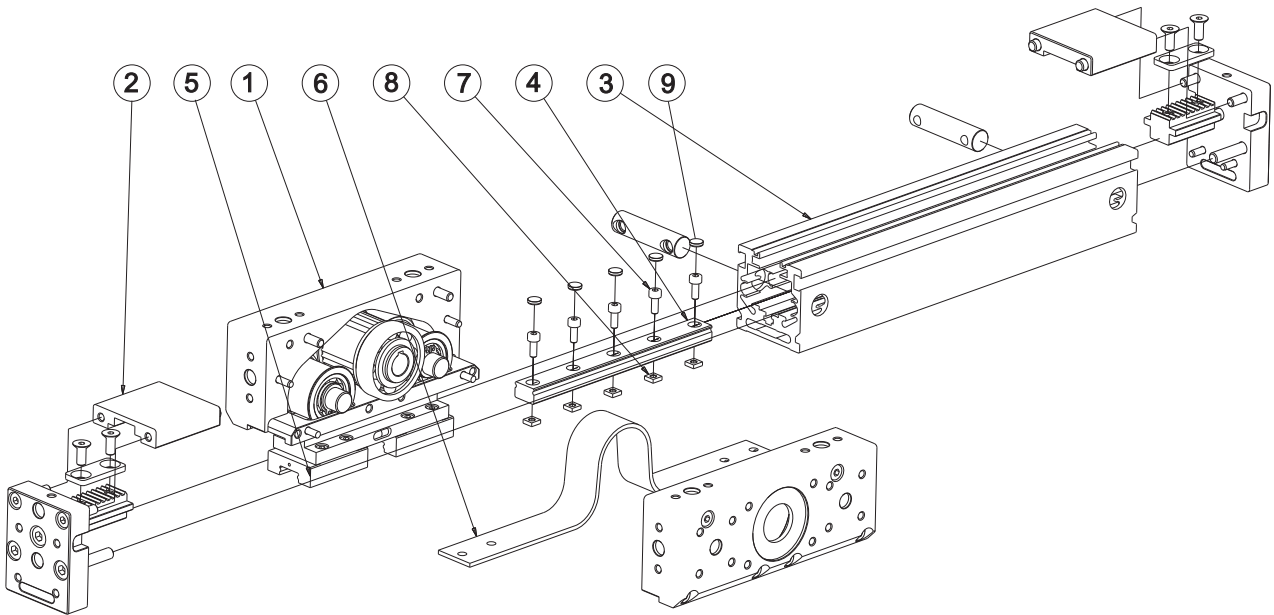

ITEM	QTY	PART NAME	LENGTH / QTY	ID
1	1	DRIVE BLOCK MTJZ 40		
		TYPE 0		44714
		TYPE 1		44715
		TYPE 2		44716
		TYPE 10		53991
		TYPE 20		54106
2	2	TENSION BLOCK MTJZ 40		44713
3	1	PROFILE MTJ / MRJ 40	STROKE + 208	36591
4	1	RAIL GUIDE MR 12 - M	STROKE + 110	8207
5	2	CARRIAGE BLOCK MINI MR12 MNSS V0-N		41478
6	1	TOOTHED BELT AT3 X 20	STROKE + 244	43239
7		ALLEN SCREW M3 x 8 DIN 912	(RAIL LENGTH/25)+0,5	52937
8		SQUARE NUT M3 DIN 562	(RAIL LENGTH/25)+0,5	37303
9		COVER FOR MR 12	(RAIL LENGTH/25)+0,5	-

ASSEMBLY MTJZ 65

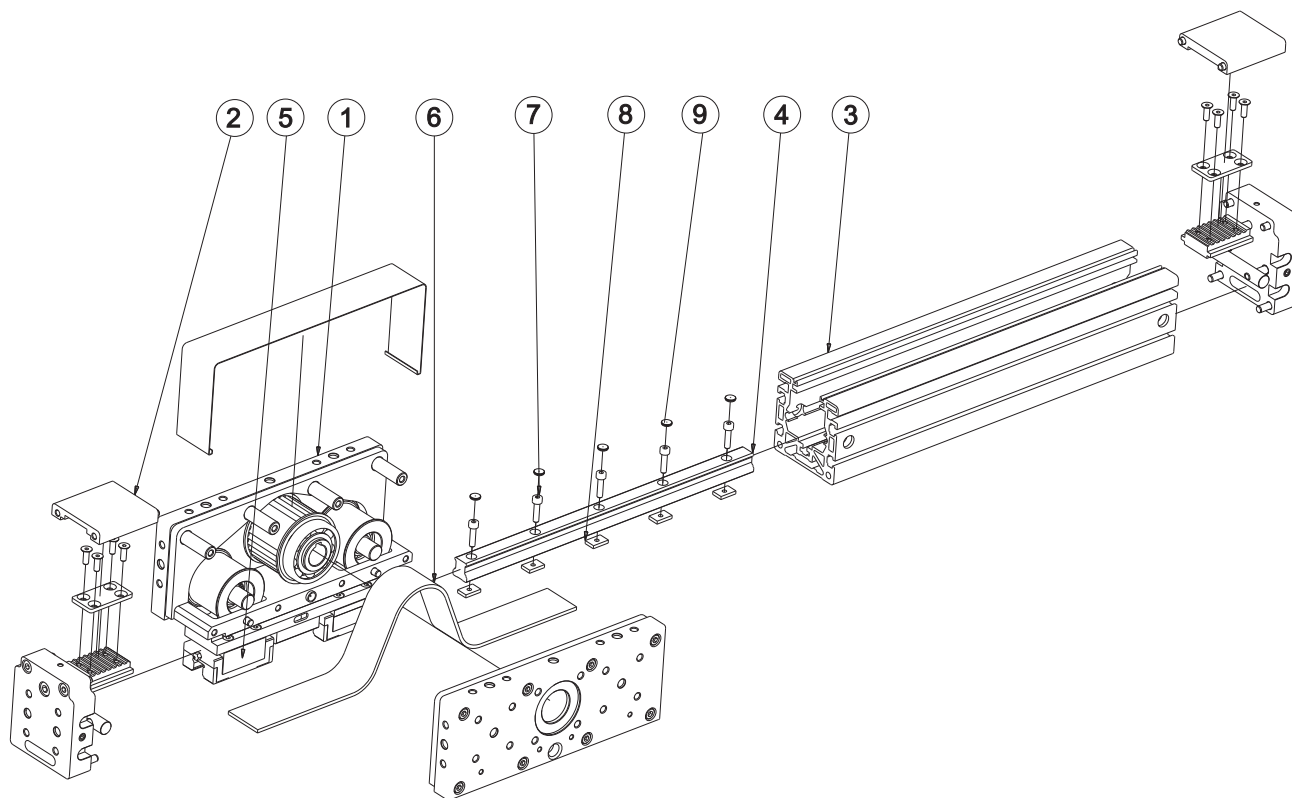

ITEM	QTY	PART NAME	LENGTH / QTY	ID
1	1	DRIVE BLOCK MTJZ 65		
		TYPE 0		41959
		TYPE 1		41960
		TYPE 2		41961
		TYPE 10		54111
		TYPE 20		54112
2	2	TENSION BLOCK MTJZ 65		41782
3	1	PROFILE MTJ / MRJ 65	STROKE + 320	36620
4	1	RAIL GUIDE AR - HR 15 N	STROKE + 270	41518
5	2	CARRIAGE BLOCK HR15MN S V1 N		41509
6	1	TOOTHED BELT AT5 X 32	STROKE + 375	41388
7		ALLEN SCREW M4 x 16 DIN 912	(RAIL LENGTH/60)+0,5	47079
8		NUT MINI 5 - M4 STRAIGHT	(RAIL LENGTH/60)+0,5	5779
9		COVER FOR AR - HR 15	(RAIL LENGTH/60)+0,5	-

ASSEMBLY MTJZ 80

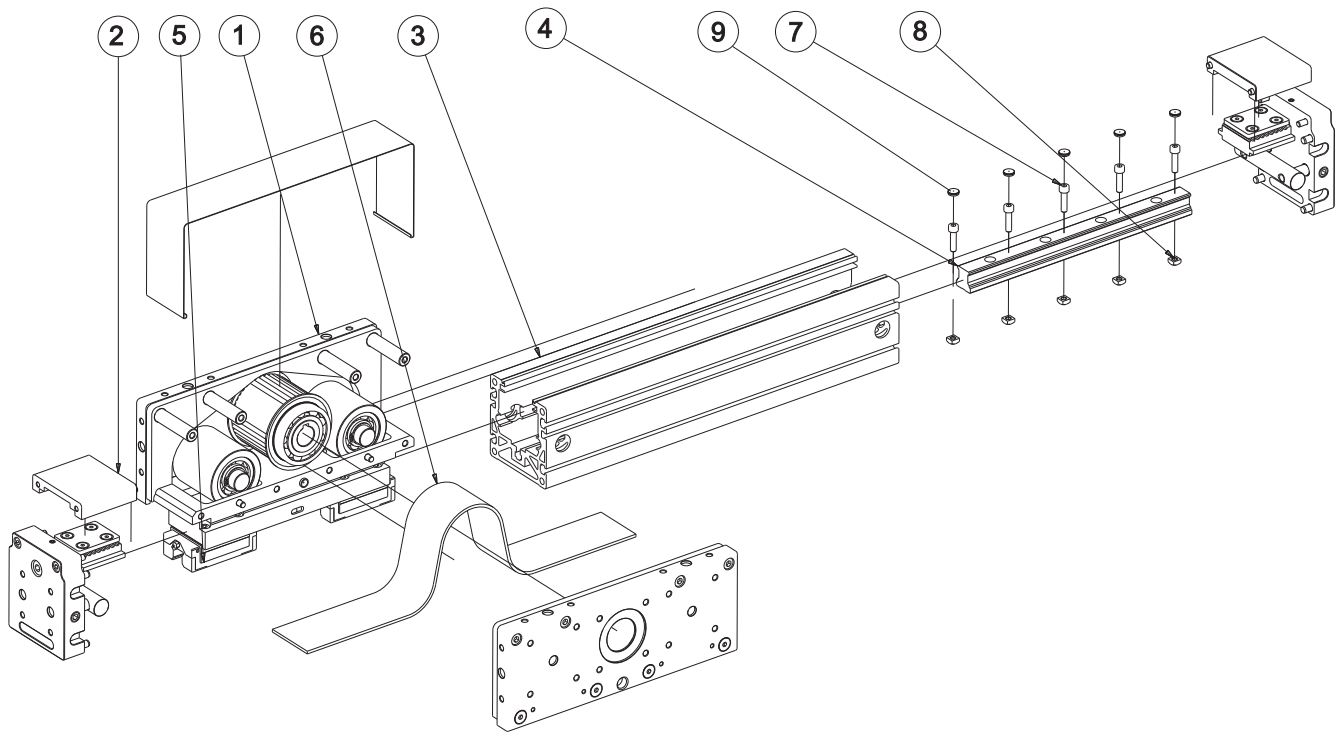

ITEM	QTY	PART NAME	LENGTH / QTY	ID
1	1	DRIVE BLOCK MTJZ 80		
		TYPE 0		47621
		TYPE 1		47622
		TYPE 2		47623
		TYPE 10		54117
		TYPE 20		54118
2	2	TENSION BLOCK MTJZ 80		47620
3	1	PROFILE MTJ / MRJ 80	STROKE + 382	36889
4	1	RAIL GUIDE AR - HR 20 N	STROKE + 262	41515
5	2	CARRIAGE BLOCK HR20MN S V1 N		41512
6	1	TOOTHED BELT AT5 X 50	STROKE + 463	36892
7		ALLEN SCREW M5 x 22 DIN 912	(RAIL LENGTH/60)+0,5	47086
8		SLOT NUT M5 DIN557	(RAIL LENGTH/60)+0,5	40769
9		COVER FOR AR - HR 20	(RAIL LENGTH/60)+0,5	-

ASSEMBLY MTJZ 110

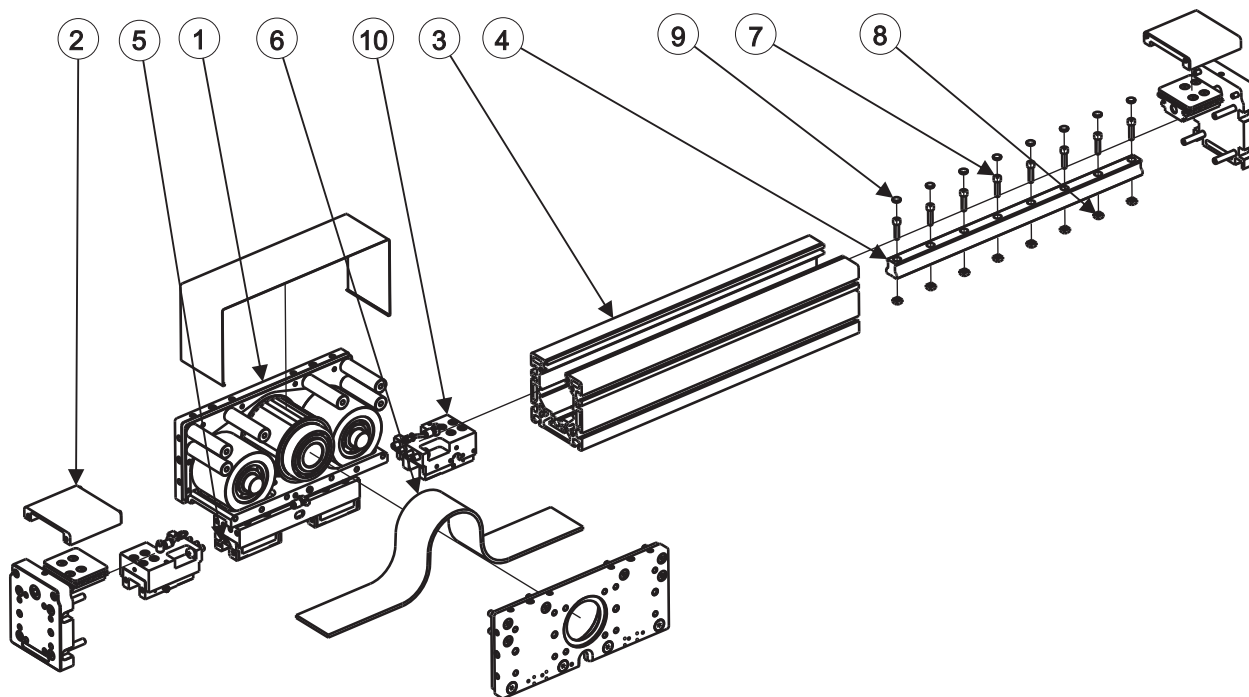

ITEM	QTY	PART NAME	LENGTH / QTY	ID
1	1	DRIVE BLOCK MTJZ 110 TYPE 0		59546
2	2	TENSION BLOCK MTJZ 110		59529
3	1	PROFILE MTJ / MRJ 110	STROKE + 382	43955
4	1	RAIL GUIDE AR - HR 25 N	STROKE + 262	42972
5	2	CARRIAGE BLOCK HR25MN S V1 N		44932
6	1	TOOTHED BELT AT10 X 70	STROKE + 463	59548
7		ALLEN SCREW M6 x 25 DIN 912	(RAIL LENGTH/60)+0,5	47070
8		SLOT NUT M6 DIN557	(RAIL LENGTH/60)+0,5	44454
9		COVER FOR AR - HR 25	(RAIL LENGTH/60)+0,5	-
10	2	EMERGENCY BRAKE BLOCK		60132

REPLACEMENT OF ASSEMBLIES - MTJZ SERIES



- any furthermentioned modifications, without our written consent, will void our liability in respect of the linear unit,
- before any operation make sure that the module is disconnected from the power grid to prevent possible injuries caused by the electrical current or moving parts,
- MTJZ 40: due to the precise fit between railguide MR 12 and carriage block Mini MR 12 both need to be replaced at the same time even if only one of them fails.

Loosening the belt

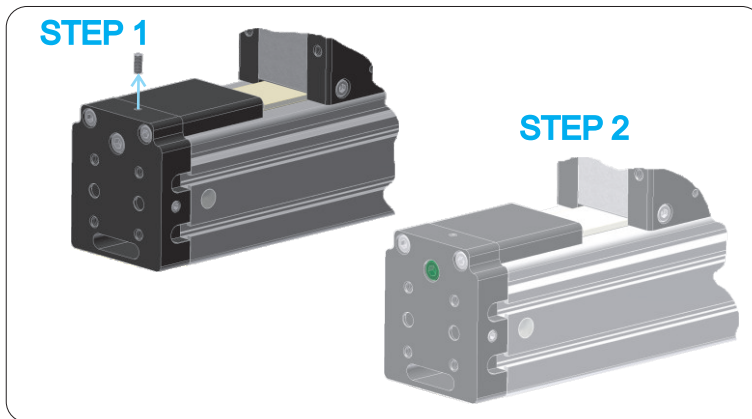

STEP 1: loosen the set screws locking tensioning screws.

STEP 2: loosen the belt by unscrewing the tensioning screws (highlighted in green).

Removing the tensioning blocks

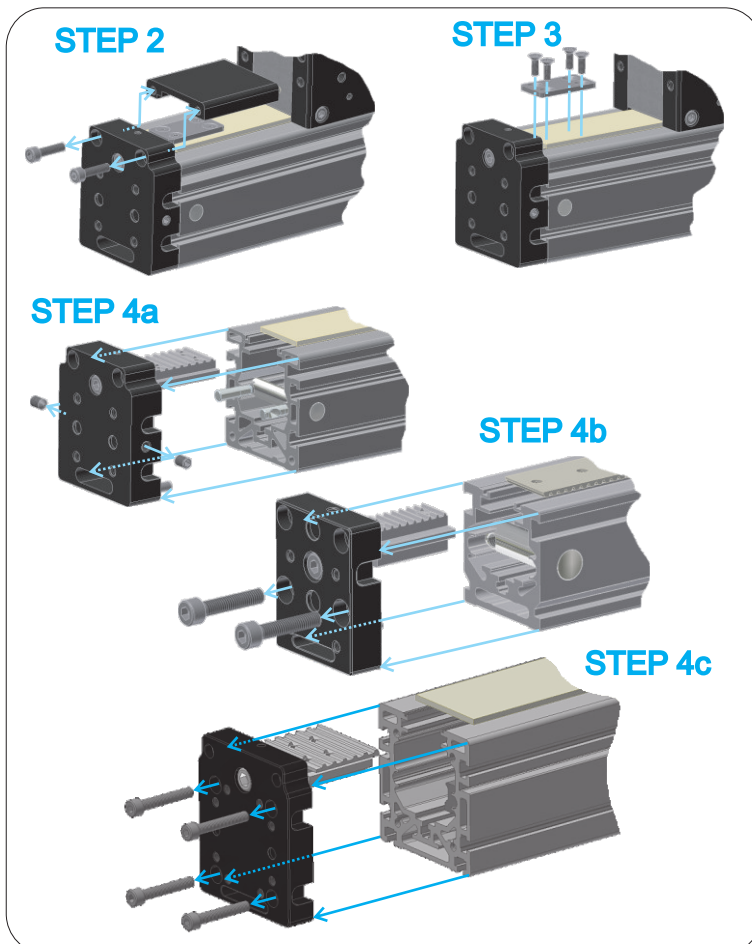

STEP 1: loosen the toothed belt.

STEP 2: remove the belt tensioner cover

STEP 3: detach the belt

STEP 4a (MTJZ 65, 80): remove the tensioning block by unscrewing the set screw on each side

STEP 4b (MTJZ 40): remove the tensioning block by unscrewing the two screws attaching the block to the profile.

STEP 4c (MTJZ 110): remove the tensioning block by unscrewing the four screws attaching the block to the profile.

Note: all the screws (except the set screws) must be glued (Loctite 243) and screwed with the torque specified in the table on page 1.005.0 unless written otherwise at the individual steps.

Replacing the toothed belt

STEP 1: loosen and detach the toothed belt on both ends and remove it from the module.

STEP 2: place the module on the side and remove one side panel and the protection cover.

STEP 3: insert new belt into the module. Start in the middle and push it under the roller so that it emerges on the side of the drive block.

Note: if needed remove the drive axle for this step.

STEP 4: install the protection cover and side panel of the drive block.

MA **STEP 5:** attach the toothed belt to the tension blocks on both ends. Tighten the attachment screws to:

MTJZ 40 - 1Nm

MTJZ 65 - 1Nm

MTJZ 80 - 1.5Nm

MTJZ 110 - 3.5 Nm

Install the belt tensioner covers.

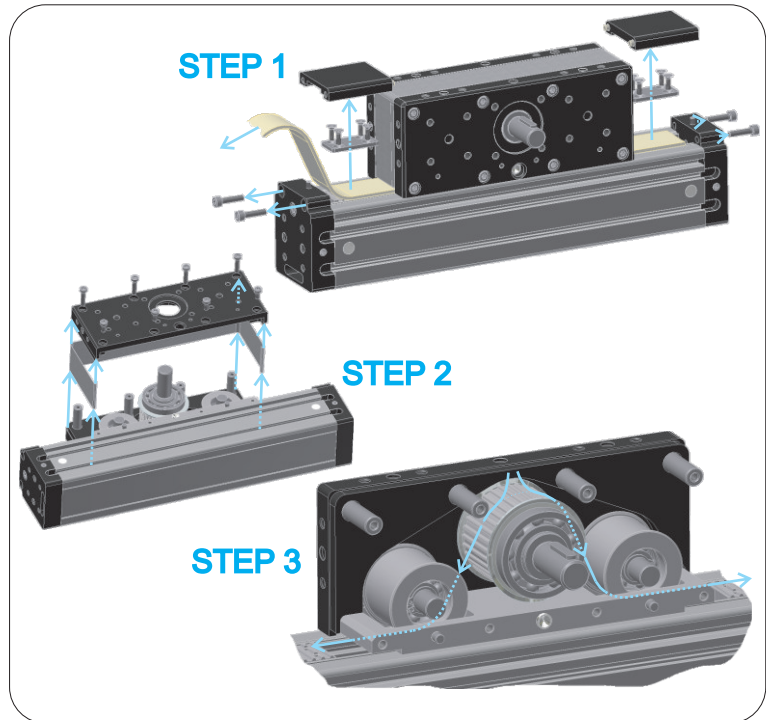

Tensioning the toothed belt

STEP 1: pretension the toothed belt by turning tensioning screws. Belt should visibly straighten but it must not be tight.

STEP 2: check the distance the belt must be tensioned with from the chart.

STEP 3: calculate the number of turns for the tensioning screws. Number of turns depends on the screw lead.

MA **STEP 4:** turn the tensioning screw at one end to tension the belt halfway and one on the other end of the carriage to tension the toothed belt to the end.

Note: prior to tensioning you can turn the axle to any orientation you want.

MA **STEP 5:** when the belt is tensioned secure the tensioning screws on both ends with the set screws.

STEP 6: install the tensioner cover.

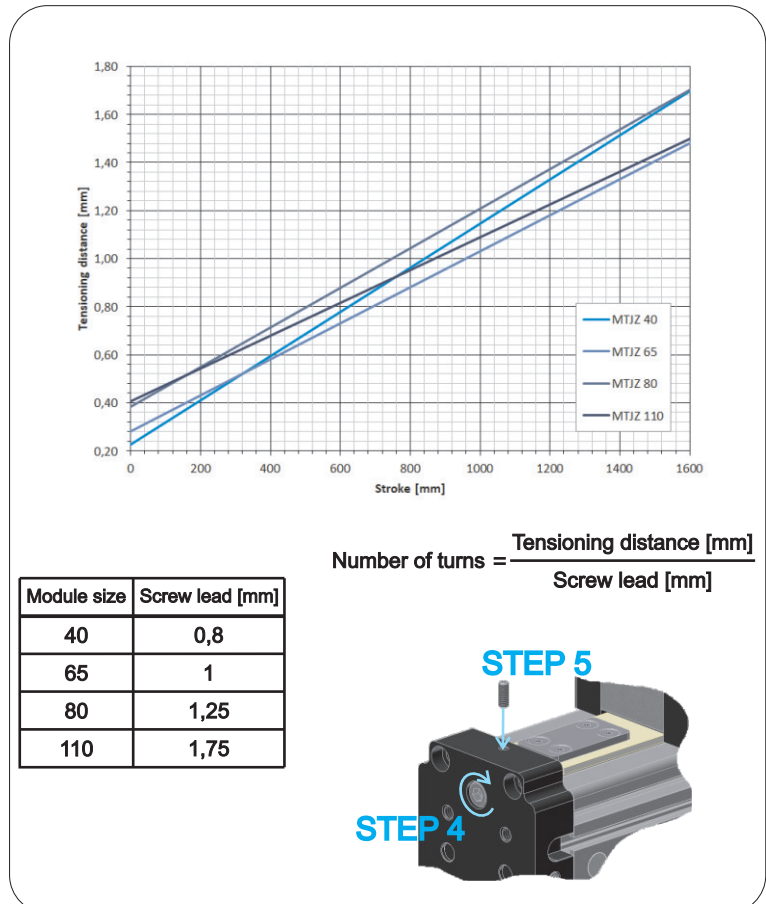

Note: all the screws (except the set screws) must be glued (Loctite 243) and screwed with the torque specified in the table on page 1.005.0 unless written otherwise at the individual steps.

Replacing the axels and/or the drive block

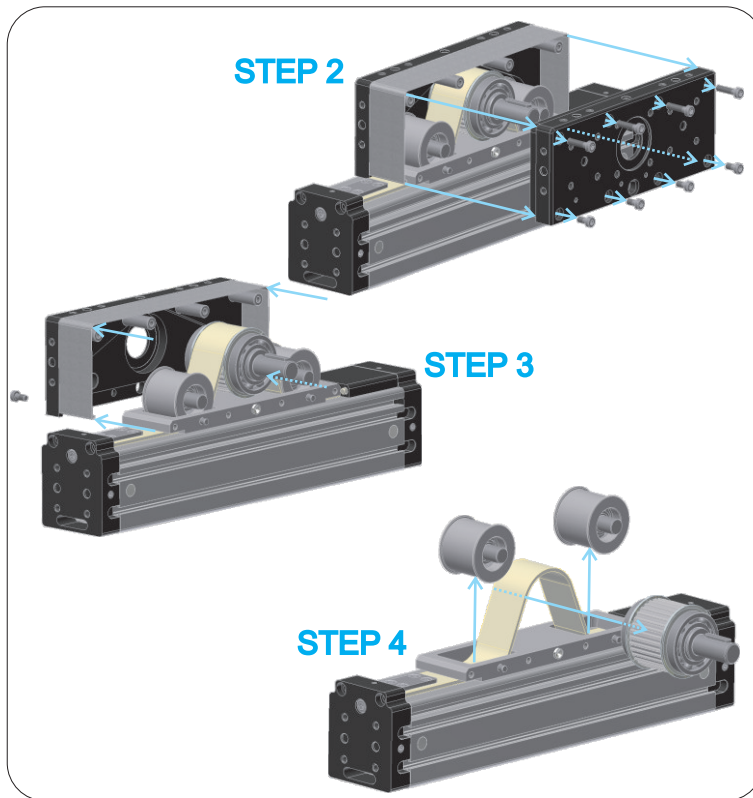

STEP 1: loosen the toothed belt.

STEP 2: remove one side panel of the drive block.

STEP 3: remove the other side panel of the drive block with axles.

STEP 4: replace axles.

STEP 5: install the side panel with the axles to the profile.

STEP 6: Install the second side panel and the steel protection cover (there is no protection cover on MTJZ 40).

STEP 7: tension the toothed belt as described in the previous chapters.

Note: the drive axle can be removed without STEP 3. It is only needed to detach the toothed belt on one side and drive axle can be removed. During the replacement of the axles it is best if the module lies on its side.

Note: use this chapter when setting the module for different application with drive shaft on the other side.

Replacing the carriage

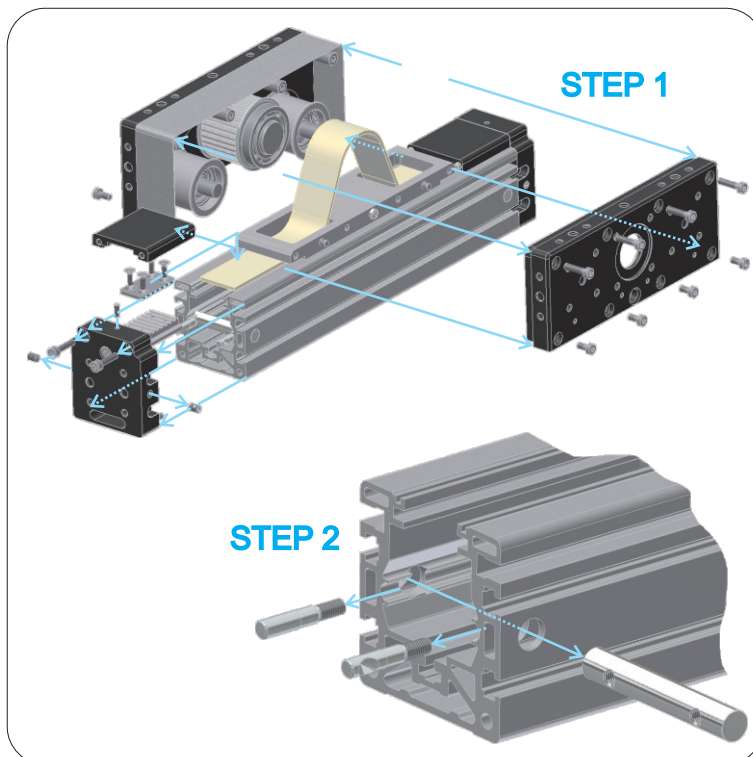

Note: when replacing the carriage consider also replacing the rail as this is the only way you can get smooth operation and desired accuracy. We recommend that you send us complete module as this is the only way we can guarantee smooth operation after replacement.

STEP 1: remove the tensioning block, drive block and the toothed belt as described in the previous chapters.

STEP 2: remove the connector from the profile (MTJZ 65, MTJZ 80).

STEP 3: replace the carriage.

Note: take care when handling the carriage without the rail, because balls may fall out of the rail guide blocks.

STEP 4: install tensioning block, toothed belt, drive block as described in the previous chapters.

STEP 5: tension the belt as described in "Tensioning toothed belt".

Note: all the screws (except the set screws) must be glued (Loctite 243) and screwed with the torque specified in the table on page 1.005.0 unless written otherwise at the individual steps.

Replacing rail

Note: when replacing the rail consider also replacing the carriage as this is the only way you can get smooth operation and a desired accuracy. We recommend that you send us complete module as this is the only way we can guarantee a smooth operation after replacement.

STEP 1: remove the tensioning blocks and the drive block with the belt. (It is not needed to dismantle the drive block. Detach the belt on both ends and remove it together with the carriage and the drive block).

 **STEP 2:** remove plastic plugs and loosen the screws that hold rail in the profile. Slide rail out of the profile.

 **STEP 3:** attach nuts and screws to a new rail (do not tighten the screws). Slide new rail into the profile.

 **STEP 4:** center the rail in the profile. To center it transversely start at one end. Center the rail in the groove using dedicated tools. When centered at this end tighten the nearest screw. Then center the rail on the other end using the same procedure. Center it also in the middle and on a few more places if the rail is longer. Tighten the screws with torque wrench and insert plastic plugs.

Tighten the screws to:

MTJZ 40 - 0.9 Nm

MTJZ 65 - 1.9 Nm

MTJZ 80 - 5.6 Nm

MTJZ 110 - 9.6 Nm

STEP 5: install the carriage with the drive block and the belt back into the profile. Install tensioning blocks and tension the belt as described in previous chapters.

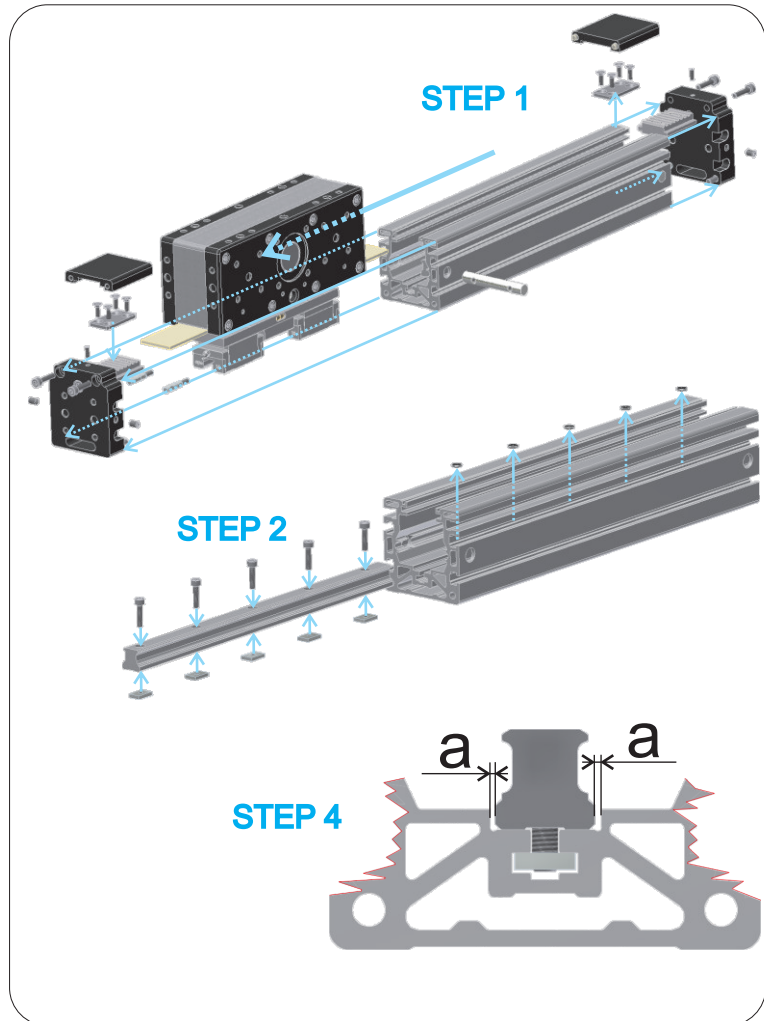

Note: all the screws (except the set screws) must be glued (Loctite 243) and screwed with the torque specified in the table on page 1.005.0 unless written otherwise at the individual steps.